

CONTENTS

SEMICONDUCTOR SHAPES 2-2

BLOCK DIAGRAM

 [AV-21D11] 2-3

 [AV-21D31] 2-5

CIRCUIT DIAGRAMS

 [AV-21D11]

MAIN PWB CIRCUIT DIAGRAM 2-7

MAIN PWB & CRT SOCKET PWB CIRCUIT DIAGRAM 2-9

 [AV-21D31]

MAIN PWB CIRCUIT DIAGRAM 2-11

MAIN PWB & CRT SOCKET PWB CIRCUIT DIAGRAM 2-13

PATTERN DIAGRAMS

 [AV-21D11]

MAIN PWB PATTERN 2-15

CRT PWB PATTERN (Within MAIN PWB) 2-19

 [AV-21D31]

MAIN PWB & CRT PWB PATTERN 2-17

CRT PWB PATTERN (Within MAIN PWB) 2-20

CHANNEL CHART 2-21

SEMICONDUCTOR SHAPES

TRANSISTOR

BOTTOM VIEW	FRONT VIEW				TOP VIEW
					CHIP TR

IC

BOTTOM VIEW	FRONT VIEW			TOP VIEW

CHIP IC

TOP VIEW	

STANDARD CIRCUIT DIAGRAM

NOTE ON USING CIRCUIT DIAGRAMS

1.SAFETY

The components identified by the Δ symbol and shading are critical for safety. For continued safety replace safety critical components only with manufactures recommended parts.

2.SPECIFIED VOLTAGE AND WAVEFORM VALUES

The voltage and waveform values have been measured under the following conditions.

- (1)Input signal : Color bar signal
- (2)Setting positions of each knob/button and variable resistor :Original setting position when shipped
- (3)Internal resistance of tester :DC 20k Ω /V
- (4)Oscilloscope sweeping time :H \Rightarrow 20 μ S/div
:V \Rightarrow 5mS/div
:Others \Rightarrow Sweeping time is specified
- (5)Voltage values :All DC voltage values

* Since the voltage values of signal circuit vary to some extent according to adjustments, use them as reference values.

3.INDICATION OF PARTS SYMBOL [EXAMPLE]

- In the PW board :R1209 \rightarrow R209

4.INDICATIONS ON THE CIRCUIT DIAGRAM

(1)Resistors

●Resistance value

- No unit :[Ω]
- K :[K Ω]
- M :[M Ω]

●Rated allowable power

- No indication :1/10 [W]
- Others :As specified

●Type

- No indication :Carbon resistor
- OMR :Oxide metal film resistor
- MFR :Metal film resistor
- MPR :Metal plate resistor
- UNFR :Uninflamable resistor
- FR :Fusible resistor

*Composition resistor 1/2 [W] is specified as 1/2S or Comp.

(2)Capacitors

●Capacitance value

- 1 or higher :[pF]
- less than 1 :[μ F]

●Withstand voltage

- No indication :DC50[V]
- Others :DC withstand voltage [V]
- AC indicated :AC withstand voltage [V]

*Electrolytic Capacitors

47/50[Example]:Capacitance value [μ F]/withstand voltage[V]

- Type
- No indication :Ceramic capacitor
- MY :Mylar capacitor
- MM :Metalized mylar capacitor
- PP :Polypropylene capacitor
- MPP :Metalized polypropylene capacitor
- MF :Metalized film capacitor
- TF :Thin film capacitor
- BP :Bipolar electrolytic capacitor
- TAN :Tantalum capacitor

(3)Coils

- No unit :[μ H]
- Others :As specified

(4)Power Supply

- :B1
- :B2(12V)
- :9V
- :5V

*Respective voltage values are indicated

(5)Test point

- :Test point
- :Only test point display

(6)Connecting method

- :Connector
- :Wrapping or soldering
- :Receptacle

(7)Ground symbol

- :LIVE side ground
- :ISOLATED(NEUTRAL) side ground
- :EARTH ground
- :DIGITAL ground

5.NOTE FOR REPAIRING SERVICE

This model's power circuit is partly different in the GND. The difference of the GND is shown by the LIVE : (\perp) side GND and the ISOLATED(NEUTRAL) : (⌚) side GND. Therefore, care must be taken for the following points.

(1)Do not touch the LIVE side GND or the LIVE side GND and the ISOLATED(NEUTRAL) side GND simultaneously. If the above caution is not respected, an electric shock may be caused. Therefore, make sure that the power cord is surely removed from the receptacle when, for example, the chassis is pulled out.

(2)Do not short between the LIVE side GND and ISOLATED(NEUTRAL) side GND or never measure with a measuring apparatus (oscilloscope, etc.) the LIVE side GND and ISOLATED(NEUTRAL) side GND at the same time. If the above precaution is not respected , a fuse or any parts will be broken.

◇ Since the circuit diagram is a standard one, the circuit and circuit constants may be subject to change for improvement without any notice.

◇ NOTE

Due improvement in performance, some part numbers show in the circuit diagram may not agree with those indicated in the part list.

When ordering parts, please use the numbers that appear in the Parts List.

BLOCK DIAGRAM

[AV-21D11]

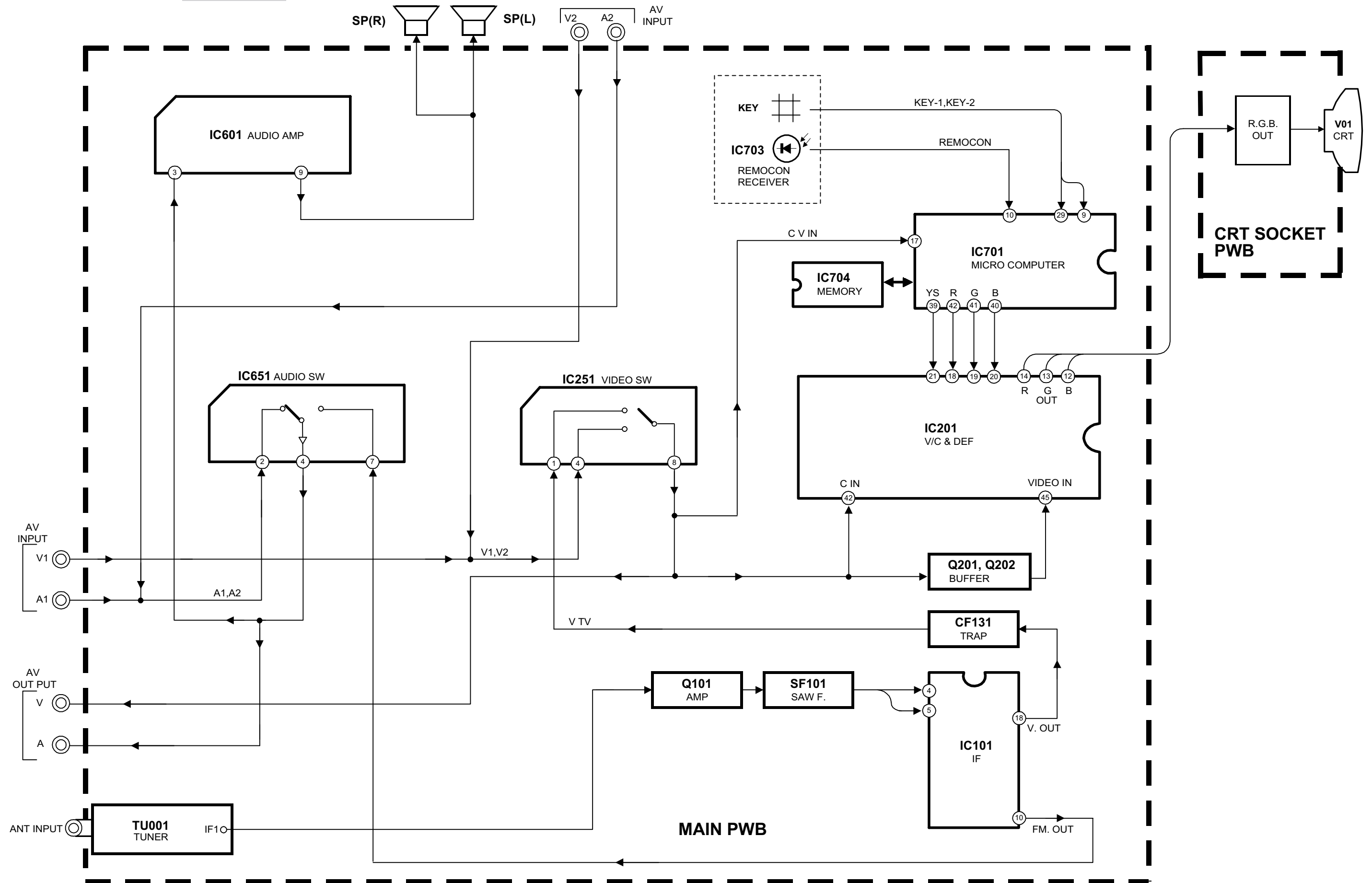

BLOCK DIAGRAM

[AV-21D31]

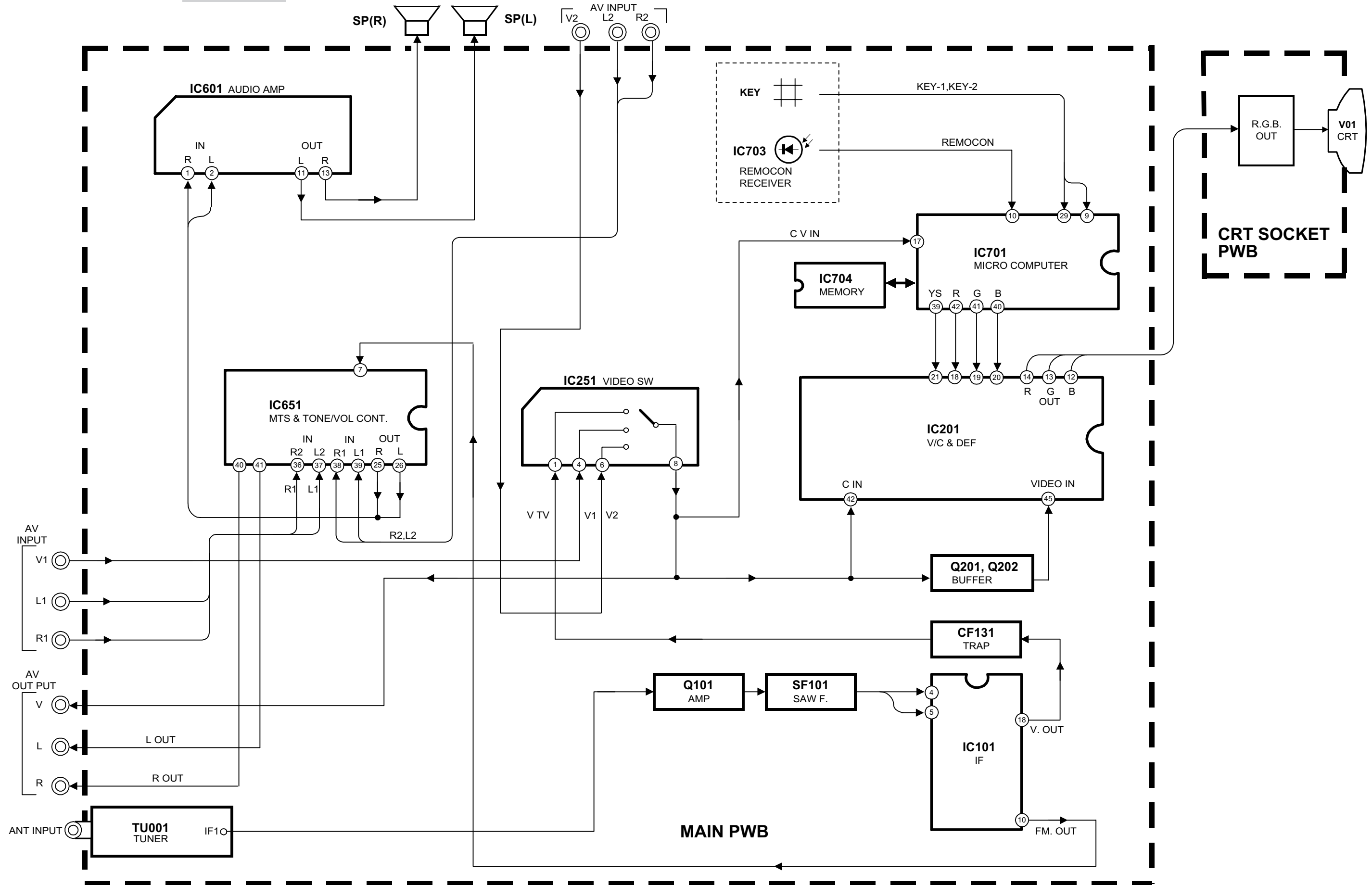

CIRCUIT DIAGRAMS

MAIN PWB CIRCUIT DIAGRAM [AV-21D11]

MAIN PWB (1/2)
SGA-1056A-H2

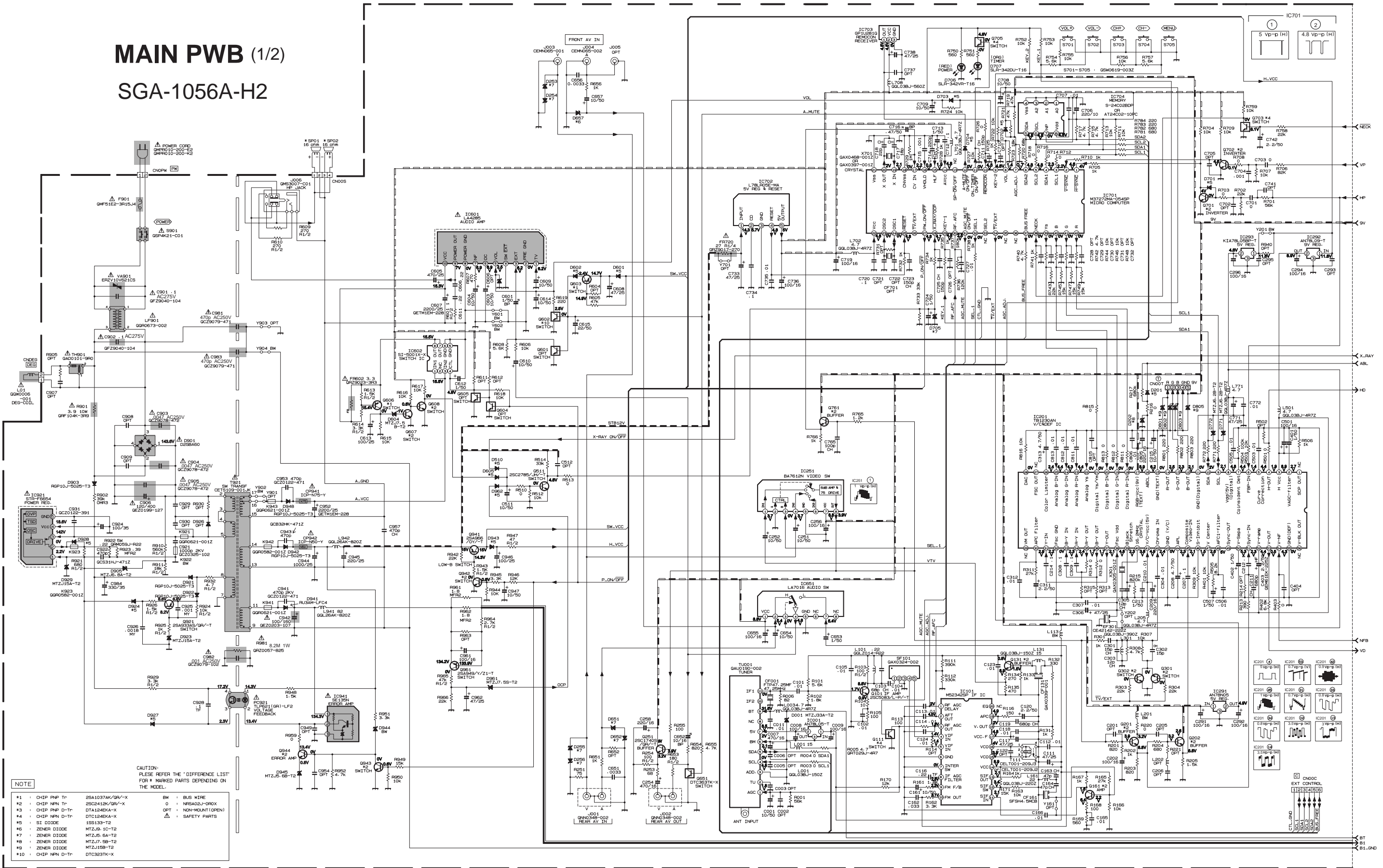

NOTE

CAUTION: PLEASE REFER THE 'DIFFERENCE LIST' FOR * MARKED PARTS DEPENDING ON THE MODEL.

*1	CHIP PNP Tr	2SA1037AK/GR-X	BW	BUS WIRE
*2	CHIP NPN Tr	2SC2412K/GR-X	0	
*3	CHIP PNP D-Tr	DTA124EKA-X	0	NON-MOUNT (OPEN)
*4	CHIP NPN D-Tr	DTL24EKA-X	Δ	SAFETY PARTS
*5	SI DIODE	1SS133-T2		
*6	ZENER DIODE	MTZJ9.1C-T2		
*7	ZENER DIODE	MTZJ5.6A-T2		
*8	ZENER DIODE	MTZJ7.5B-T2		
*9	ZENER DIODE	MTZJ15B-T2		
*10	CHIP NPN D-Tr	DTC323TK-X		

MAIN PWB & CRT SOCKET PWB CIRCUIT DIAGRAM [AV-21D11]

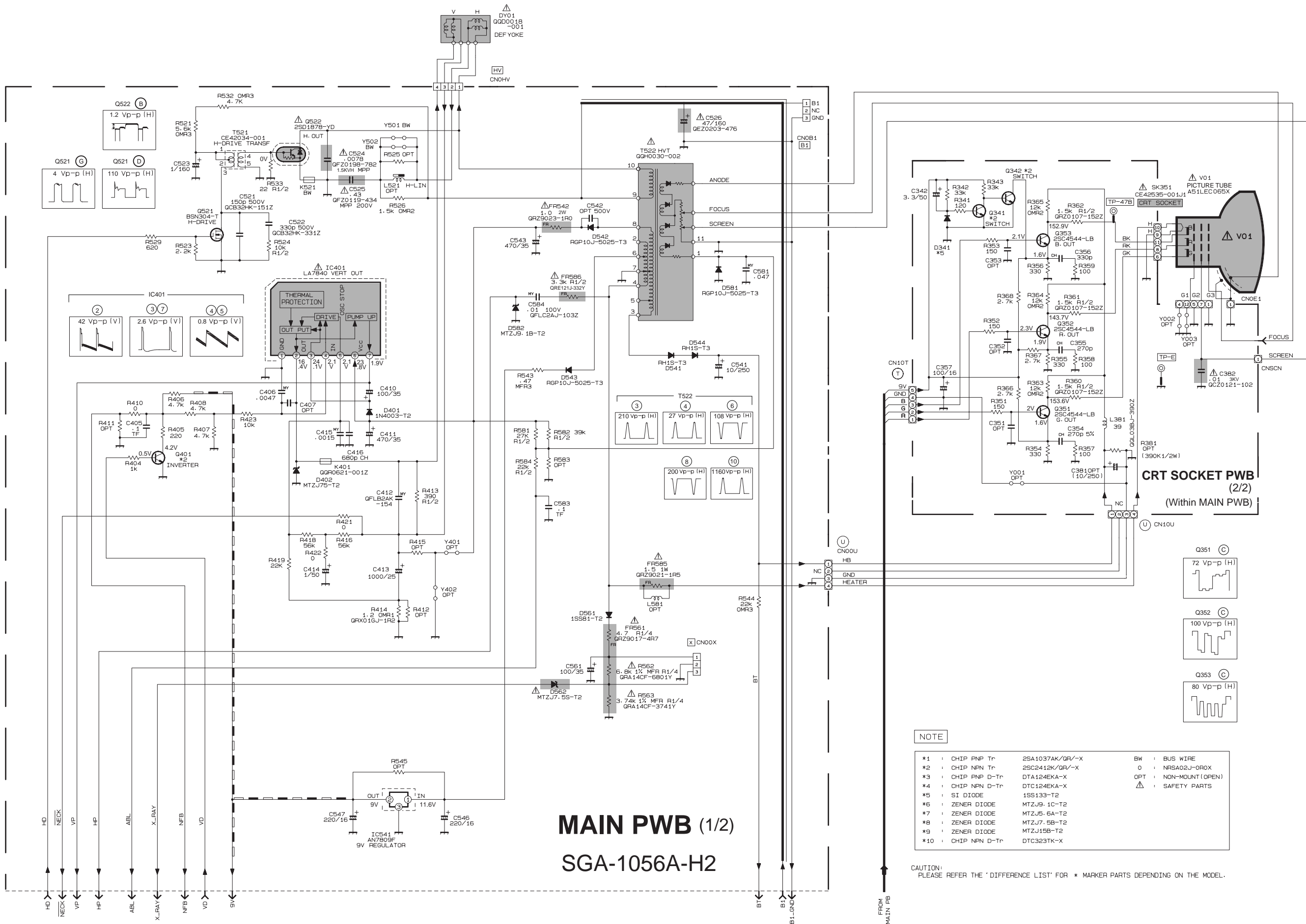

MAIN PWB (1/2)
SGA-1056A-H2

NOTE

*1 : CHIP PNP Tr	2SA1037AK/QR/-X	BW	: BUS WIRE
*2 : CHIP NPN Tr	2SC2412K/QR/-X	O	: NPSA02J-OROX
*3 : CHIP PNP D-Tr	DTA124EKA-X	OPT	: NON-MOUNT (OPEN)
*4 : CHIP NPN D-Tr	DTC124EKA-X	Δ	: SAFETY PARTS
*5 : SI DIODE	1SS133-T2		
*6 : ZENER DIODE	MTZJ9.1C-T2		
*7 : ZENER DIODE	MTZJ5.6A-T2		
*8 : ZENER DIODE	MTZJ7.5B-T2		
*9 : ZENER DIODE	MTZJ15B-T2		
*10 : CHIP NPN D-Tr	DTC323TK-X		

CAUTION: PLEASE REFER THE 'DIFFERENCE LIST' FOR * MARKER PARTS DEPENDING ON THE MODEL.

MAIN PWB (1/2) SGA-1053A-H2

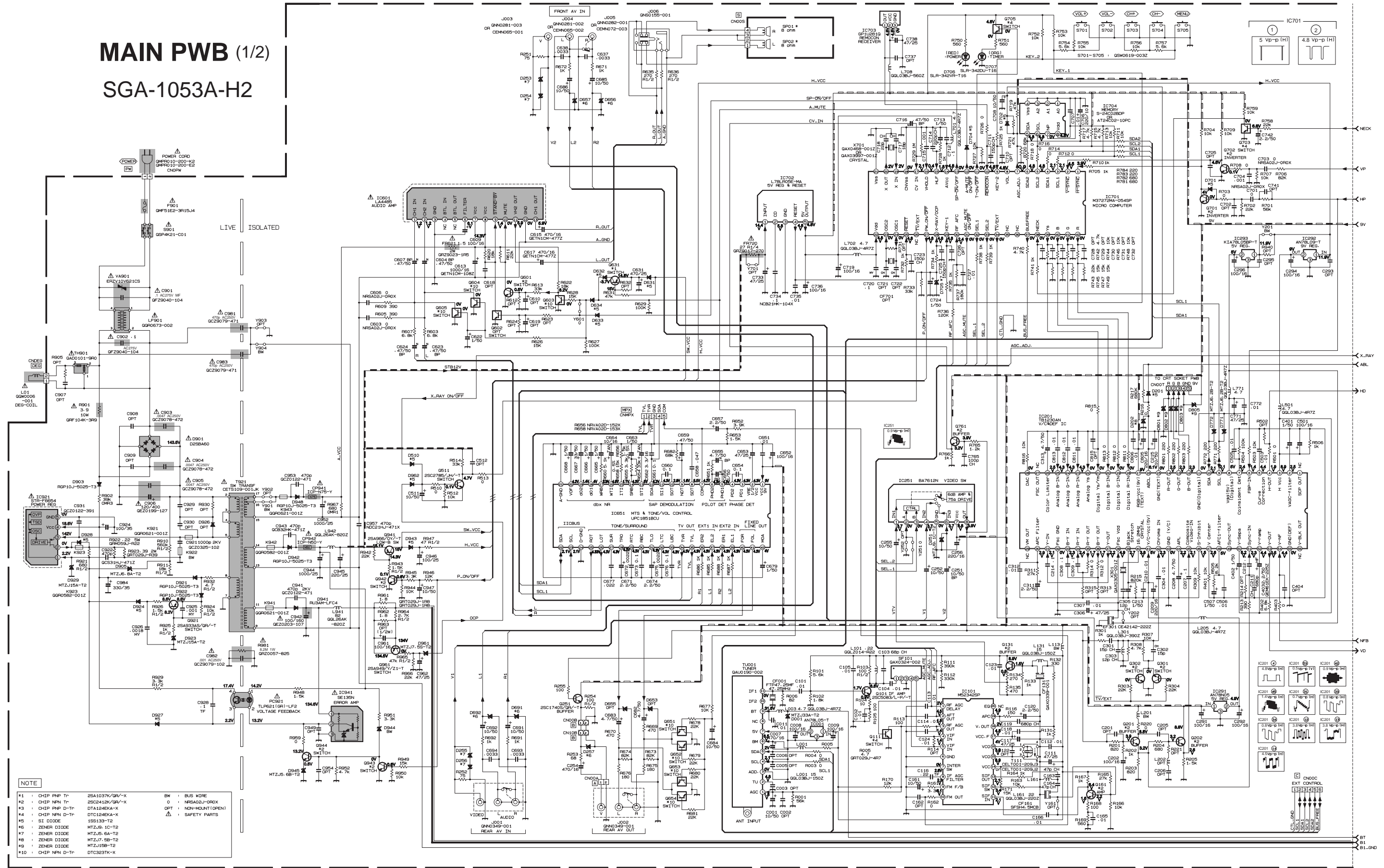

NOTE

#1	CHIP PNP Tr	2SA1037K/GR-X	BW	BUS WIRE
#2	CHIP NPN Tr	2SC2412K/GR-X	0	NFSA02J-OROX
#3	CHIP PNP D-Tr	DTA124EKA-X	OPT	NON-MOUNT (OPEN)
#4	CHIP NPN D-Tr	DTC124EKA-X	Δ	SAFETY PARTS
#5	SI DIODE	1SS133-T2		
#6	ZENER DIODE	MTZJ6.1C-T2		
#7	ZENER DIODE	MTZJ5.6A-T2		
#8	ZENER DIODE	MTZJ7.5B-T2		
#9	ZENER DIODE	MTZJ45B-T2		
#10	CHIP NPN D-Tr	DTC323TK-X		

MAIN PWB & CRT SOCKET PWB CIRCUIT DIAGRAM [AV-21D31]

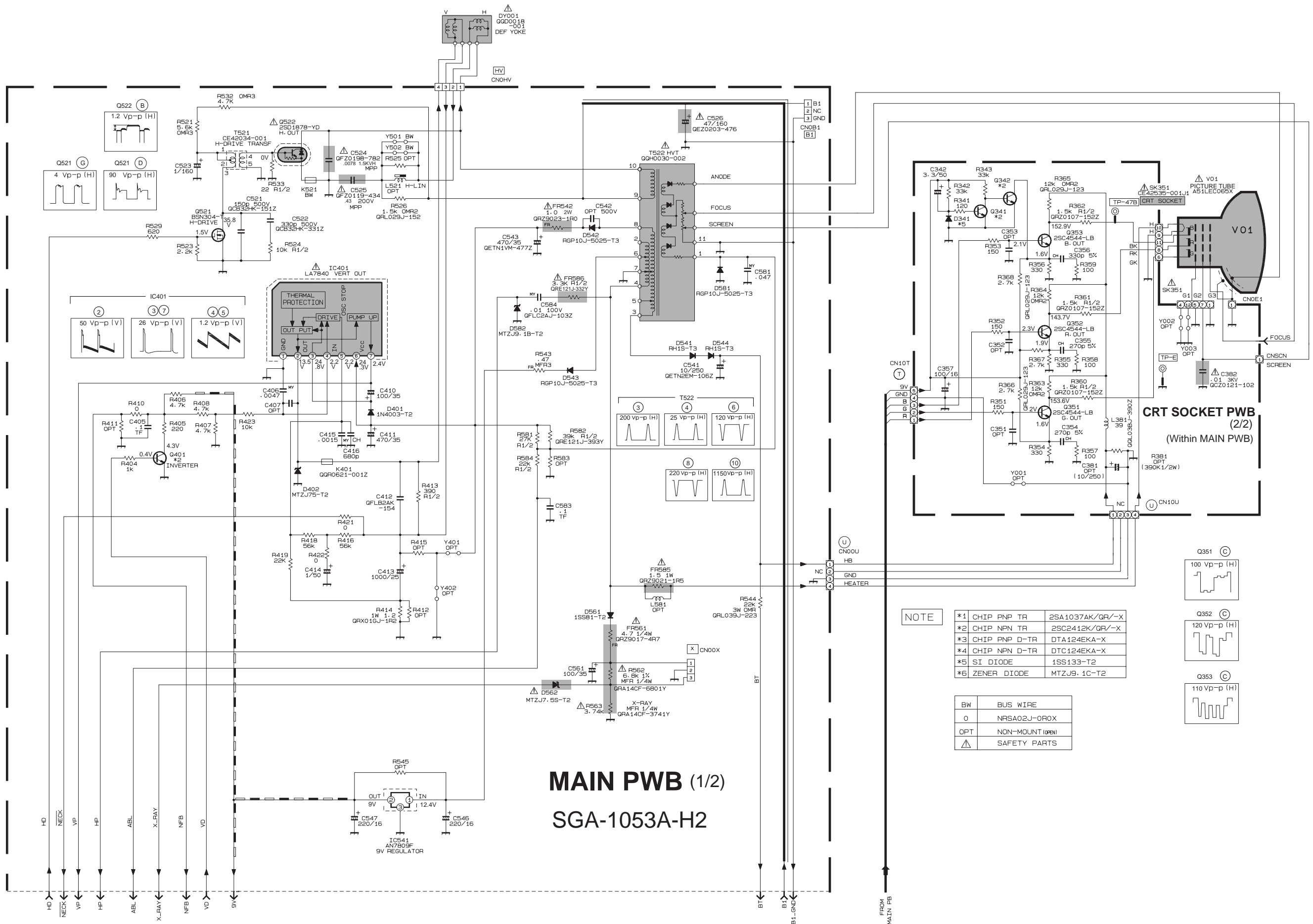

MAIN PWB (1/2)
SGA-1053A-H2

CRT SOCKET PWB (2/2)
(Within MAIN PWB)

NOTE

*1	CHIP PNP TR	2SA1037AK/QR/-X
*2	CHIP NPN TR	2SC2412K/QR/-X
*3	CHIP PNP D-TR	DTA124EKA-X
*4	CHIP NPN D-TR	DTC124EKA-X
*5	SI DIODE	1SS133-T2
*6	ZENER DIODE	MTZJ9.1C-T2

BW	BUS WIRE
0	NRSA02J-OROX
OPT	NON-MOUNT (OPEN)
△	SAFETY PARTS

PATTERN DIAGRAMS

MAIN PWB PATTERN [AV-21D11]

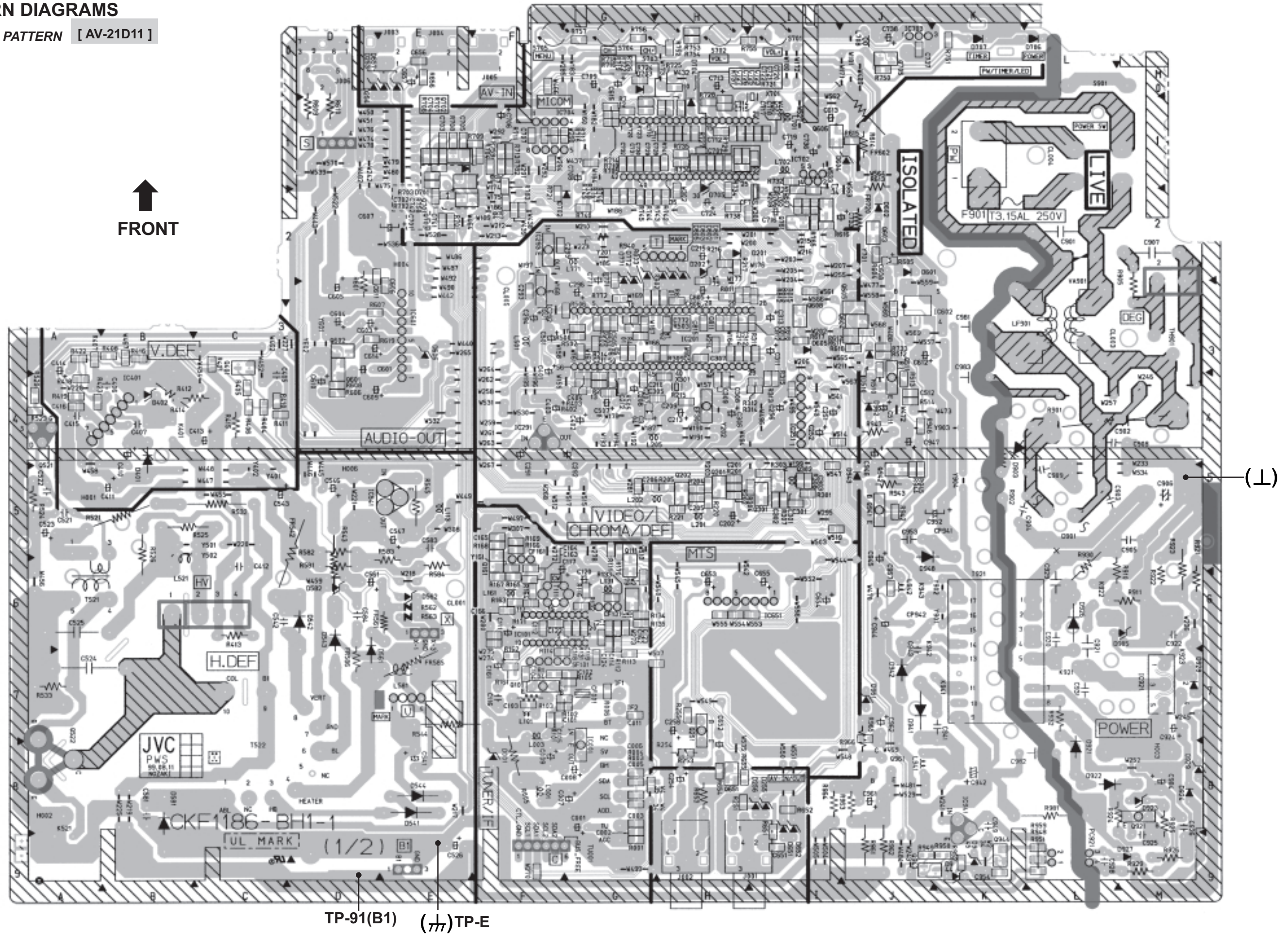

MAIN PWB PATTERN [AV-21D31]

↑
FRONT

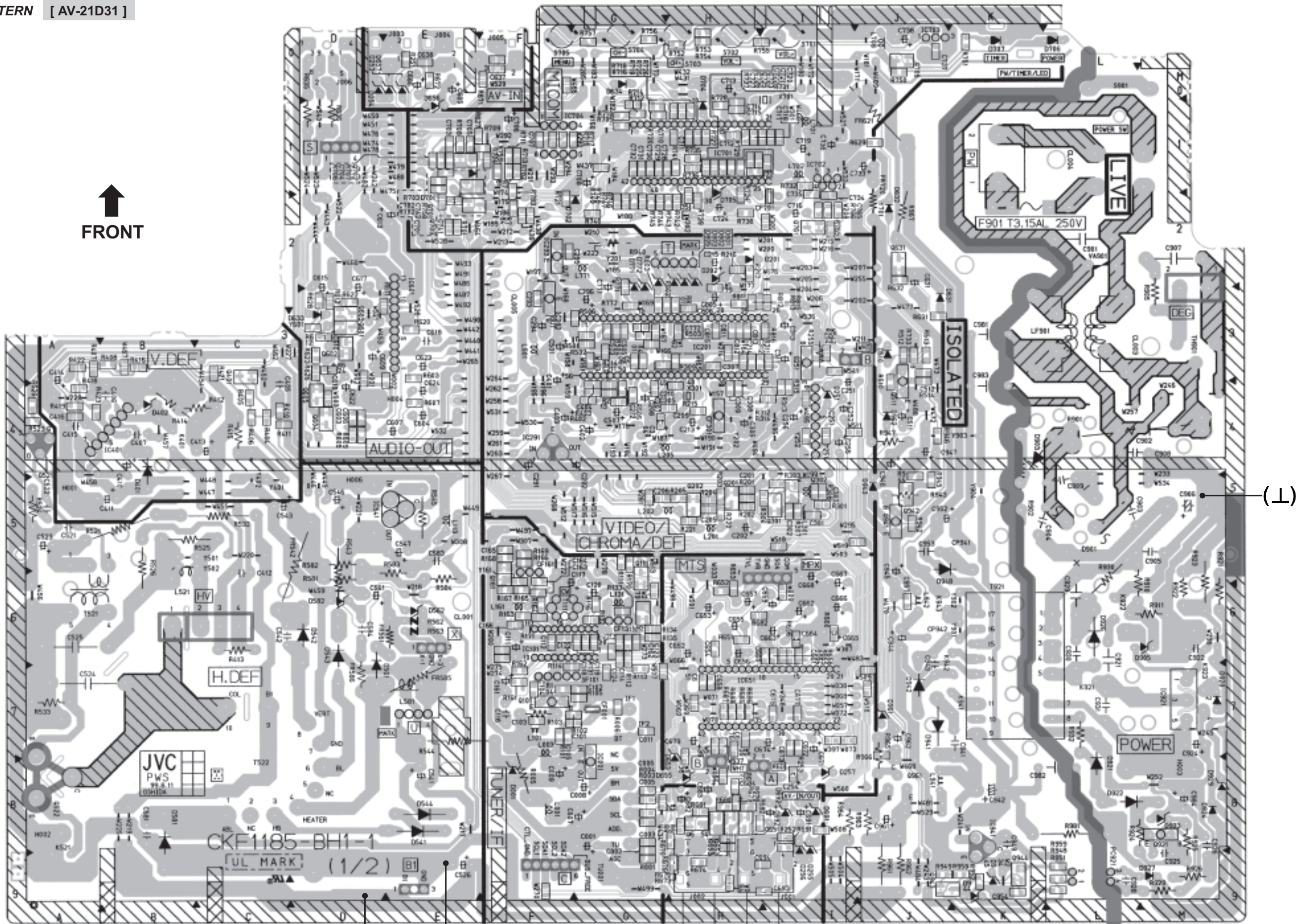

(1)

TP-91(B1) (TP-E)

CRT SOCKET PWB PATTERN (Within MAIN PWB) [AV-21D11]

CRT SOCKET PWB PATTERN (Within MAIN PWB) [AV-21D31]

↑ TOP

↑ TOP

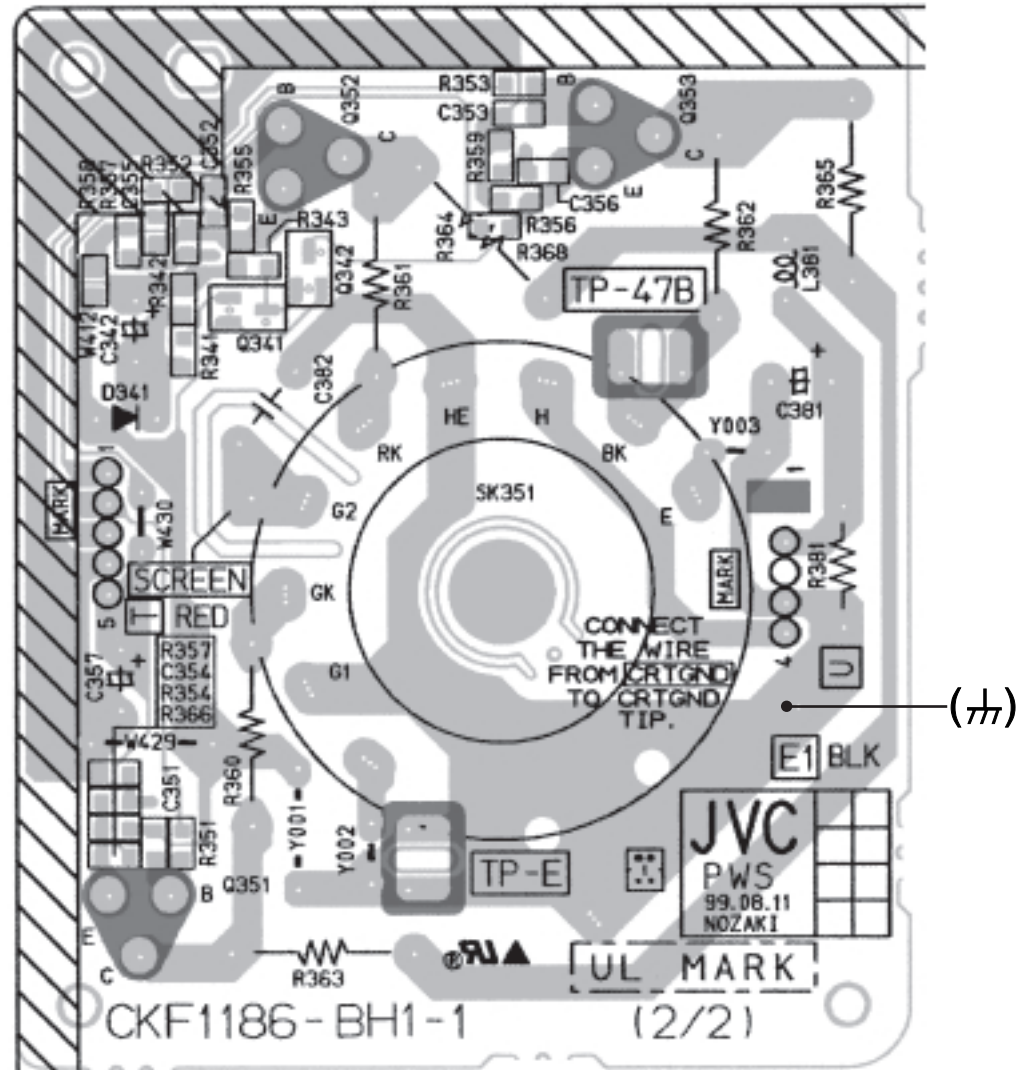

(T)

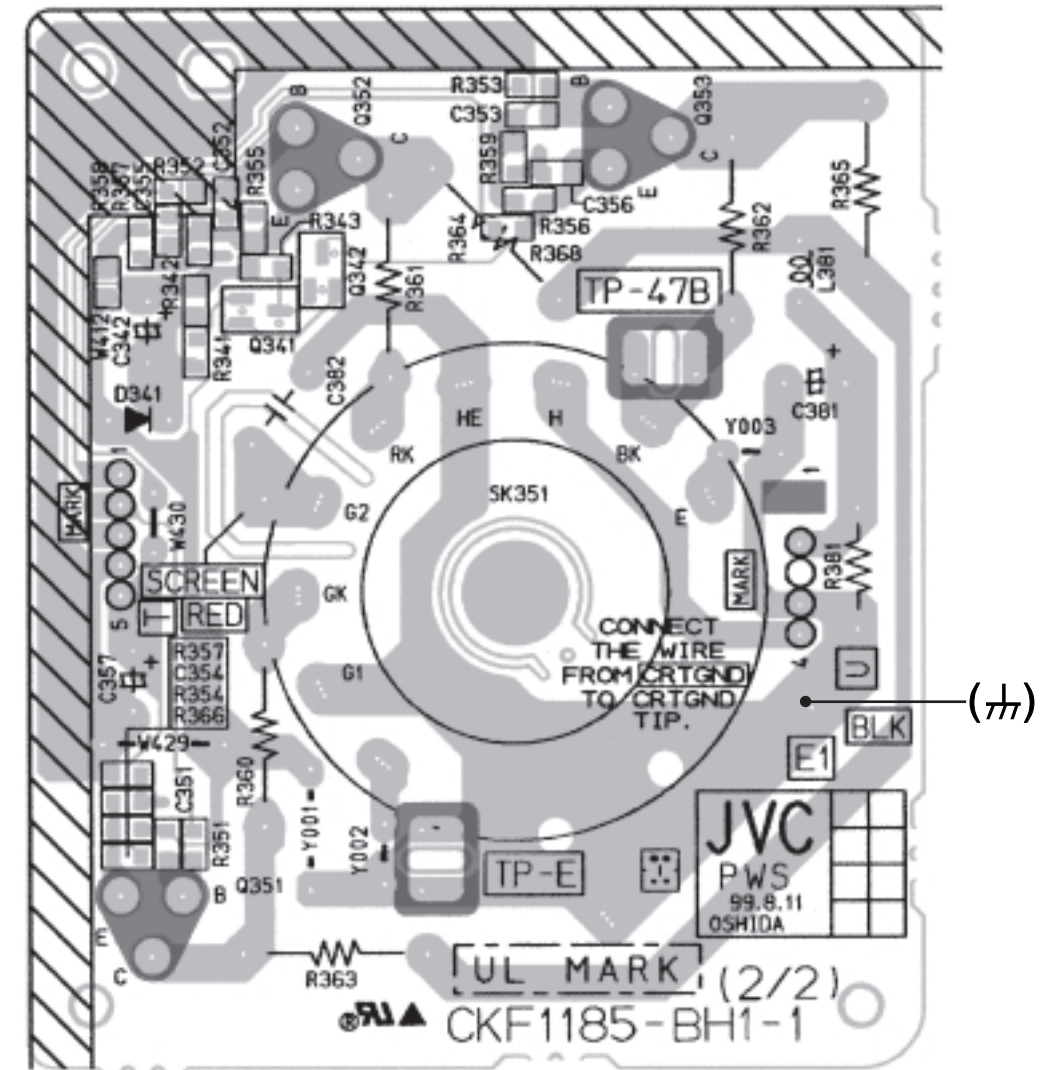

(T)

CHANNEL CHART

MODE		BAND	CHANNEL	TUNER BAND
TV	CATV		DISP.	
○	○	VL	02	I
			03	
			04	
		05		
		06		
		07		
	VH	08	II	
		09		
		10		
		11		
		12		
		13		
		14		I
15				
MID	16	II		
	17			
	18			
	19			
	20			
	21			
	22			
	SUPER		23	II
			24	
			25	
			26	
			27	
28				
29				
30				
31				
32				
33				
34				
35				
36				
HYPER		37	IV	
	38			
	39			
	40			
	41			
	42			
	43			
	44			
	45			
	46			
	47			
	48			
	49			
	50			
	51			
	52			
	53			
	54			
55				
56				
57				
58				
59				
60				
61				
62				
63				
64				
ULTRA	65	IV		
	66			
	67			
	68			
	69			
	70			

MODE		BAND	CHANNEL	TUNER BAND
TV	CATV		DISP.	
x	○	ULTRA	71	IV
			72	
			73	
			74	
			75	
			76	
			77	
			78	
			79	
			80	
			81	
			82	
			83	
			84	
			85	
			86	
			87	
			88	
			89	
			90	
			91	
			92	
			93	
			94	
			100	
101				
102				
103				
104				
105				
106				
107				
108				
109				
110				
111				
112				
113				
114				
115				
116				
117				
118				
119				
120				
121				
122				
123				
124				
125				
○	x	SUB MID	01	I
			96	
			97	
			98	
○	x	UHF	14	IV
			69	
			69	
TOTAL 180CH { VHF 124CH { UHF 56CH				
NOTE: TO RECEIVE THE SUBSCRIPTION OR PREMIUM PROGRAMMING FROM CERTAIN CABLE COMPANIES. SPECIAL ADAPTERS MAY BE REQUIRED.				